

HOBART701 S Ridge Avenue, Troy, OH 45374
1-888-4HOBART • www.hobartcorp.com**UW50
UTENSIL/PAN WASHER****HOBART****STANDARD FEATURES**

- 2.1 gallons of water per rack
- 19 racks per hour
- Timed wash cycles for 2, 4 or 6 minutes
- Stainless steel tank, tank shelf, chamber, trim panels, frame and feet
- Solid state heat controls
- Front loading, split-door configuration
- Flat-bottomed, stainless steel frame rack, with one flat grid rack and two tray support racks
- Chamber accepts 16 full-sized sheet pans, or 140-quart mixing bowl
- Two upper and two lower revolving, debossed non-clogging stainless steel wash arms
- Two upper and lower revolving stainless steel rinse arms
- Heavy-duty door and door hinges
- Large, removable stainless steel scrap screen and scrap bucket
- 10 KW electric tank heat
- 15 KW electric booster heater
- Stainless steel front panel
- Integrated detergent connections
- Top-mounted dial thermometers
- Door actuated drain closer
- Heavy-duty 5 H.P. motor
- Door interlock switch
- Corrosion-resistant impeller
- Timed fill
- Positive low water protection
- Spray hose (standard on electric booster heater equipped models only)

VOLTAGE

- 208/60/3
- 240/60/3
- 480/60/3

MODEL

- UW50

OPTIONS AT EXTRA COST

- Vent fan control (option for electric heat machines only)
- Steam coil tank heat
- 15 KW electric booster heater (option for steam coil machines only)

ACCESSORIES

- Power vent fan kit
- Drain water tempering kit
- Rack insert for 30" trays
- Spray hose assembly (field installed for non-booster equipped machines only)
- 20" x 20" peg or combination racks

Specifications, Details and Dimensions on Inside and Back.



(Electric machines only)

**UW50 UTENSIL/PAN WASHER**

UW50 UTENSIL/PAN WASHER



701 S Ridge Avenue, Troy, OH 45374
1-888-4HOBART • www.hobartcorp.com

DETAILS & DIMENSIONS – ELECTRIC

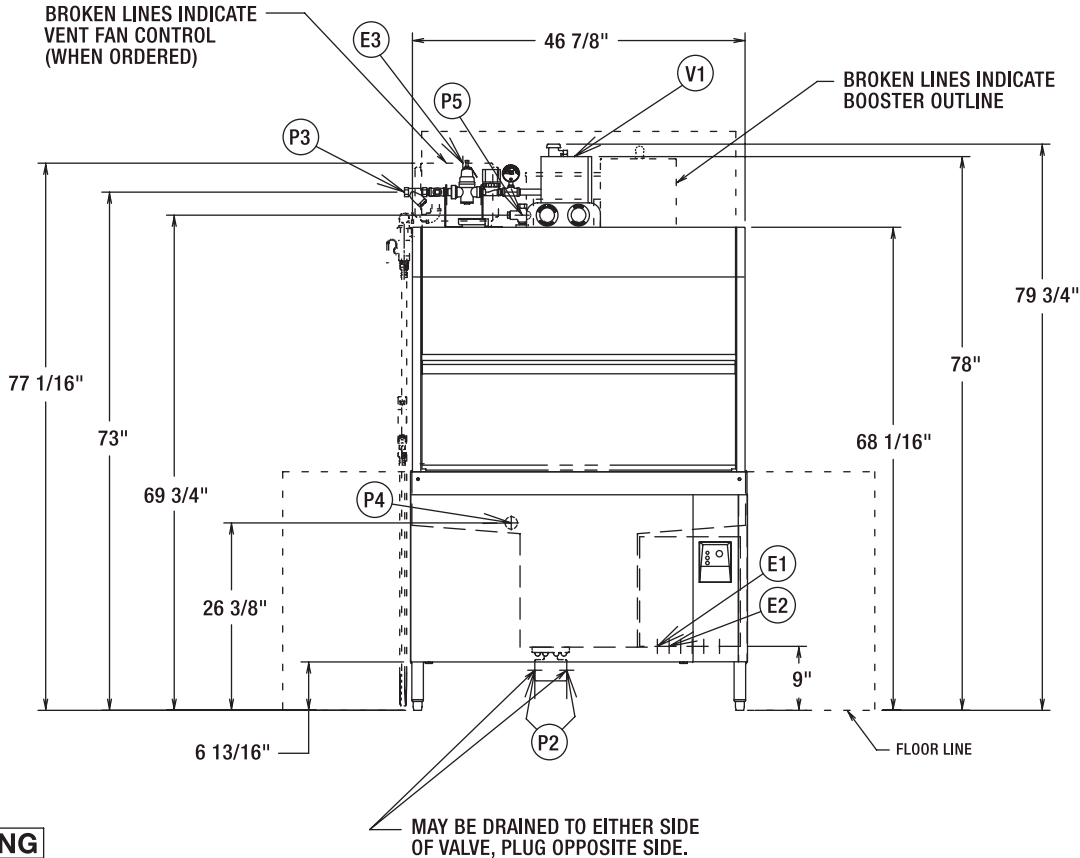

⚠ WARNING

Electrical and grounding connections must comply with the applicable portions of the National Electrical Code and/or other local electrical codes.

Plumbing connections must comply with applicable sanitary, safety and plumbing codes. Drain and fill line configurations vary, some methods are shown on this drawing.

PLUMBING NOTES:

Water hammer arrestor (meeting ASSE-1010 STANDARD or equivalent) to be supplied (by others) in common water supply line at service connection. Recommended water hardness to be 3 grains or less for best results.

Recommended building flowing water pressure to the dishwasher is 20-25 PSI.

Pressure regulator furnished.

For convenience when cleaning, water tap should be installed near machine with heavy duty hose and squeeze valve.

MISCELLANEOUS NOTES:

All dimensions taken from floor line may be increased by up to 1-1/8" with leg adjustment.

Net weight of machine: 678 lbs. w/booster
Domestic shipping weight: 820 lbs. w/booster

Shipping dimensions:
60" X 38" X 85" high.

Size of racks:
40-7/8" X 22-7/8" X 4-1/8"

Drain lever located inside of tank.

CONNECTION INFORMATION (*AFF - ABOVE FINISHED FLOOR)

LEGEND

- E1 ELECTRICAL CONNECTION (INCLUDING ELECTRIC HEAT) 1-1/4" CONDUIT HOLE, 9" AFF.
- E2 ELECTRICAL CONNECTION-DETERGENT/RINSE AGENT FEEDERS: 1/2" CONDUIT HOLE; 9" AFF
- E3 ELECTRICAL CONNECTION-VENT FAN CONTROL (WHEN ORDERED); 3/4" CONDUIT HOLE; 77-1/16" AFF
- P2 DRAIN: 2" FPT, 5-5/8" AFF TWO CONNECTIONS.
- P3 COMMON WATER CONNECTION WITH BOOSTER 110°F MIN., 1/2" FPT, 73" AFF.
- P4 DETERGENT PROBE SENSOR: REMOVE CAP AND STUD ASSEMBLY TO ACCESS 7/8" HOLE, 26-3/8" AFF
- P5 RINSE AGENT FEEDER: 1/8" NPT, REMOVE 1/8" NPT PIPE PLUG TO ACCESS TAPPED HOLE; 69-3/4" AFF.
- V1 VENT EXIT: 7" X 11" X 10" HIGH TO ALLOW FOR EXPANSION OF AIR. (NEED NOT BE CONNECTED TO EXTERNAL VENT); IF REQUIRED, VENT HOOD TO PROVIDE 400 CFM EXHAUST.

SINGLE POINT ELECTRIC CONNECTION UW-50 WITH 10KW ELECTRIC HEAT AND 15KW ELECTRIC BOOSTER (CONTROLS AND SHP PUMP MOTOR)			
ELEC. SPECS.	RATED AMPS	MINIMUM SUPPLY CIRCUIT CONDUCTOR AMPACITY	MAXIMUM OVERCURRENT PROTECTIVE DEVICE
208/60/3	93.9	100 Δ	100
240/60/3	86.3	100 Δ	100
480/60/3	43.8	50	50

Δ FOR SUPPLY CONNECTION USE WIRES SUITABLE FOR AT LEAST 90°C OR EQUIVALENT.



701 S Ridge Avenue, Troy, OH 45374
1-888-4HOBART • www.hobartcorp.com

UW50 UTENSIL/PAN WASHER

DETAILS & DIMENSIONS – ELECTRIC

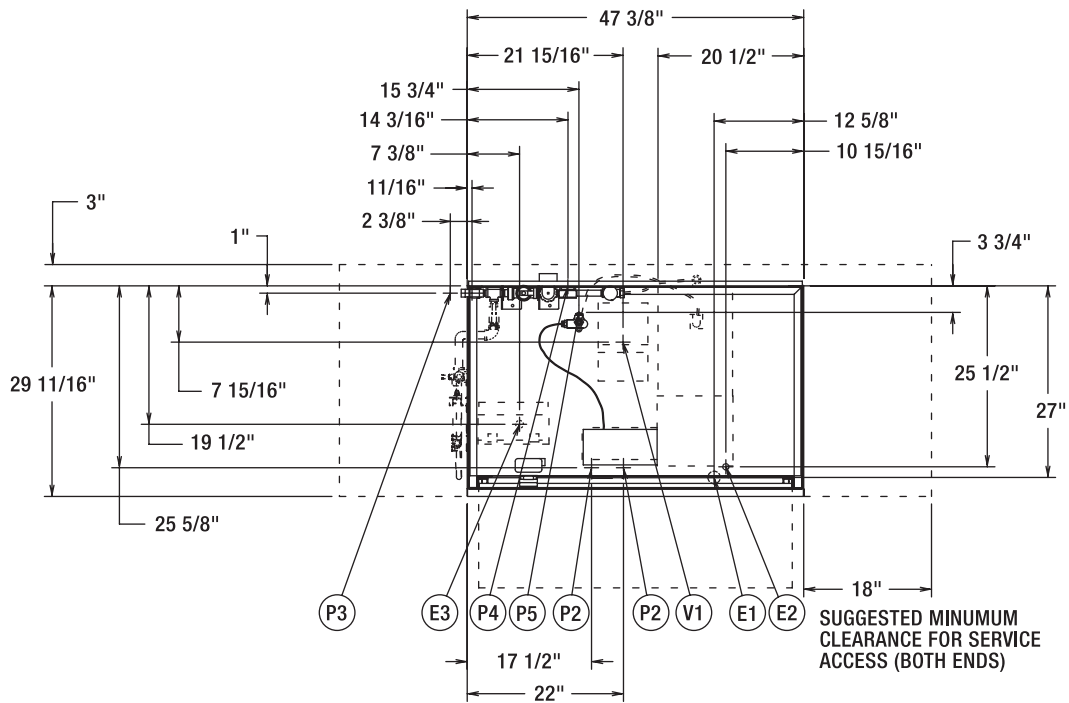
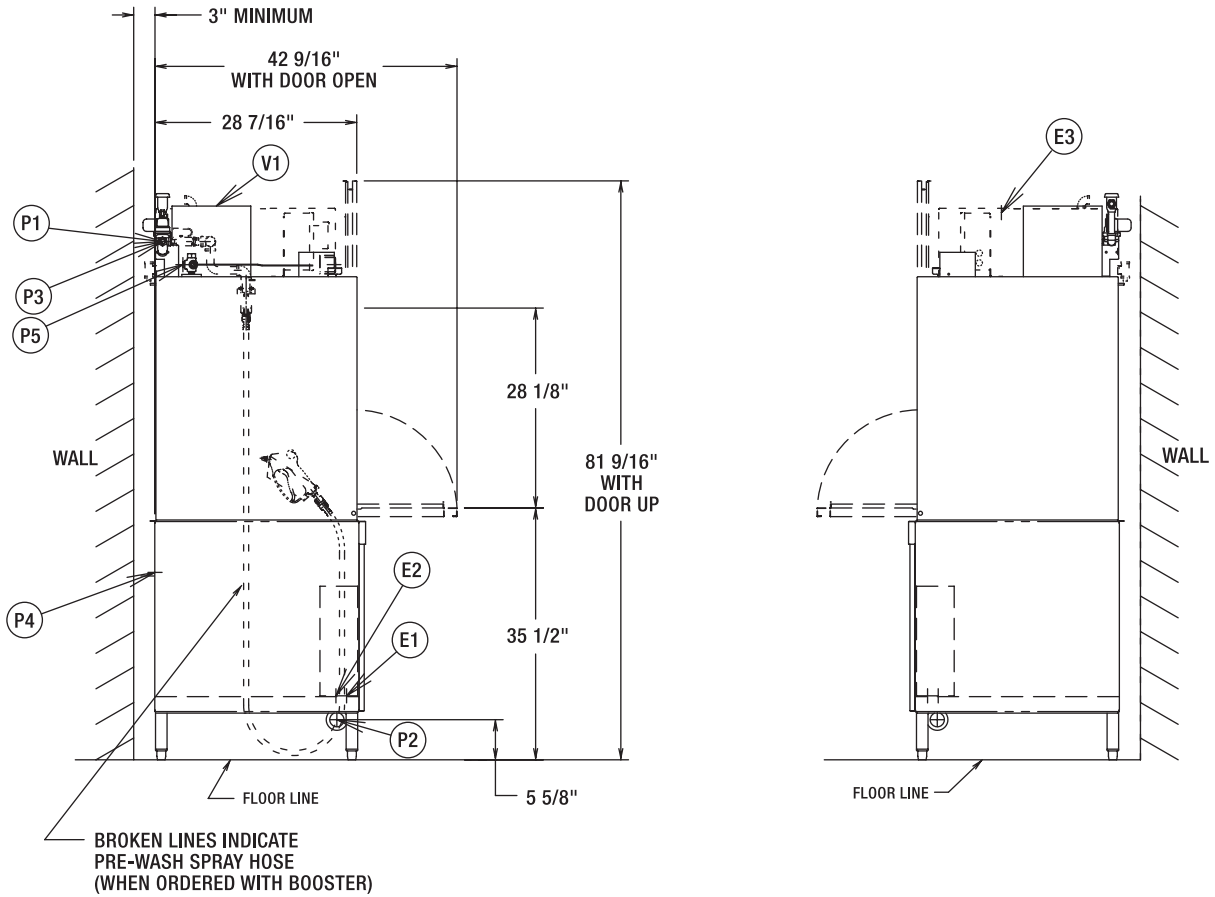

MODEL: UW-50
ELECTRIC
00-812969
REV D

UW50 UTENSIL/PAN WASHER



701 S Ridge Avenue, Troy, OH 45374
1-888-4HOBART • www.hobartcorp.com

DETAILS & DIMENSIONS – STEAM COIL

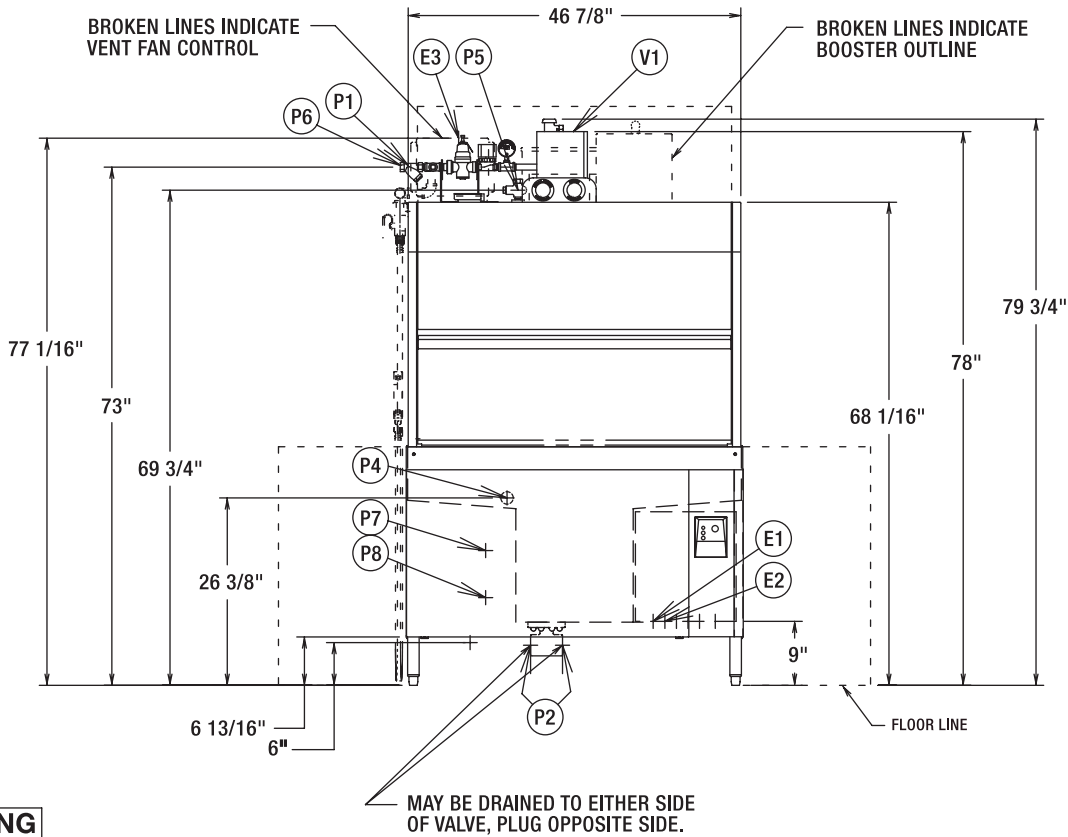

WARNING

Electrical and grounding connections must comply with the applicable portions of the National Electrical Code and/or other local electrical codes.

Plumbing connections must comply with applicable sanitary, safety and plumbing codes. Drain and fill line configurations vary, some methods are shown on this drawing.

PLUMBING NOTES:

Water hammer arrestor (meeting ASSE-1010 STANDARD or equivalent) to be supplied (by others) in common water supply line at service connection.

Recommended water hardness to be 3 grains or less for best results.

Recommended building flowing water pressure to the dishwasher is 20-25 PSI.

Pressure regulator furnished.

For convenience when cleaning, water tap should be installed near machine with heavy duty hose and squeeze valve.

MAY BE DRAINED TO EITHER SIDE OF VALVE, PLUG OPPOSITE SIDE.

CONNECTION INFORMATION (*AFF - ABOVE FINISHED FLOOR)

LEGEND

- E1 ELECTRICAL CONNECTION (MOTOR & CONTROLS): 1-1/4" CONDUIT HOLE, 9" AFF.
- E2 ELECTRIC CONNECTION-DETERGENT/RINSE AGENT FEEDERS: 1/2" CONDUIT HOLE; 9" AFF
- E3 ELECTRIC CONNECTION-VENT FAN CONTROL (WHEN ORDERED); 3/4" CONDUIT HOLE; 77-1/16" AFF
- P1 COMMON WATER CONNECTION: 180°F WATER MIN., 3/4" FPT, 73" AFF.
- P2 DRAIN: 2" FPT, 5-5/8" AFF TWO CONNECTIONS.
- P4 DETERGENT PROBE SENSOR: REMOVE CAP AND STUD ASSEMBLY TO ACCESS 7/8" HOLE, 26-3/8" AFF
- P5 RINSE AGENT FEEDER: 1/8" NPT, REMOVE 1/8" NPT PIPE PLUG TO ACCESS TAPPED HOLE; 69-3/4" AFF.
- P6 COMMON WATER CONNECTION WITH ELECTRIC BOOSTER (WHEN ORDERED); 110°F MIN., 3/4" FPT, 73" AFF.
- P7 STEAM COIL: 10 TO 25 PSI FLOWING, 50 PSI MAX., 3/4" FPT, 19" AFF.
- P8 CONDENSATE RETURN: 10 TO 50 PSI FLOWING, 3/4" FPT, 12-3/8" AFF, (BUCKET TYPE TRAP FURNISHED).
- V1 VENT EXIT: 7" X 11" X 10" HIGH TO ALLOW FOR EXPANSION OF AIR. (NEED NOT BE CONNECTED TO EXTERNAL VENT); IF REQUIRED, VENT HOOD TO PROVIDE 400 CFM EXHAUST.

MISCELLANEOUS NOTES:

All dimensions taken from floor line may be increased by up to 1-1/8" with leg adjustment.

Net weight of machine: 640 lbs. w/o booster
Domestic shipping weight: 782 lbs. w/o booster

Net weight of machine: 678 lbs. w/booster
Domestic shipping weight: 820 lbs. w/booster

Shipping dimensions:
60" X 38" X 85" high.

Size of racks:
40-7/8" X 22-7/8" X 4-1/8"

Drain lever located inside of tank.

SINGLE POINT ELECTRIC CONNECTION UW-50 WITH STEAM HEAT (CONTROLS AND 5HP PUMP MOTOR)			
ELEC. SPECS.	RATED AMPS	MINIMUM SUPPLY CIRCUIT CONDUCTOR AMPACITY	MAXIMUM OVERCURRENT PROTECTIVE DEVICE
208/60/3	20.3	25	25
240/60/3	17.6	25	25
480/60/3	9.2	15	15

SINGLE POINT ELECTRIC CONNECTION UW-50 WITH STEAM HEAT AND 15KW ELECTRIC BOOSTER (CONTROLS AND 5HP PUMP MOTOR)			
ELEC. SPECS.	RATED AMPS	MINIMUM SUPPLY CIRCUIT CONDUCTOR AMPACITY	MAXIMUM OVERCURRENT PROTECTIVE DEVICE
208/60/3	64.7	80	80
240/60/3	59.4	70	70
480/60/3	29.9	35	35



701 S Ridge Avenue, Troy, OH 45374
1-888-4HOBART • www.hobartcorp.com

UW50 UTENSIL/PAN WASHER

DETAILS & DIMENSIONS – STEAM COIL

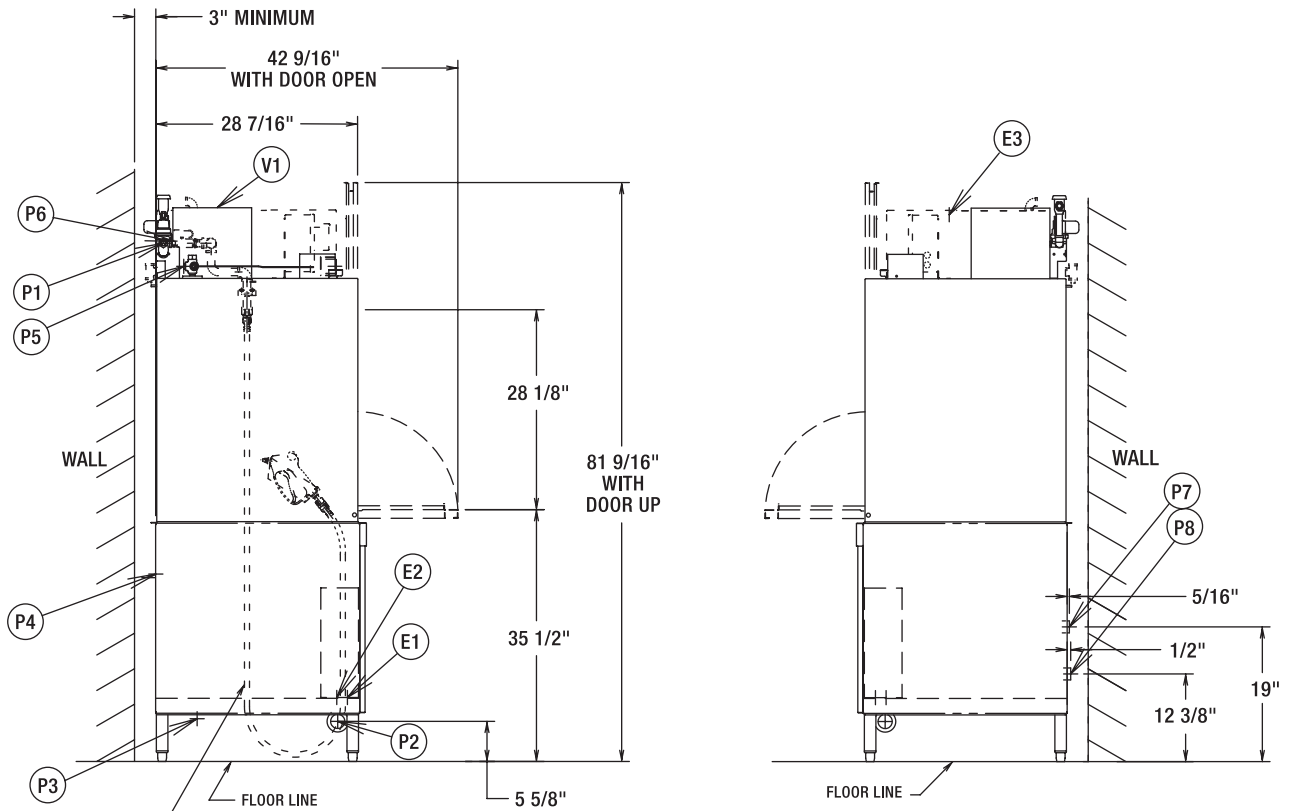

BROKEN LINES INDICATE
PRE-WASH SPRAY HOSE
(WHEN ORDERED WITH BOOSTER)

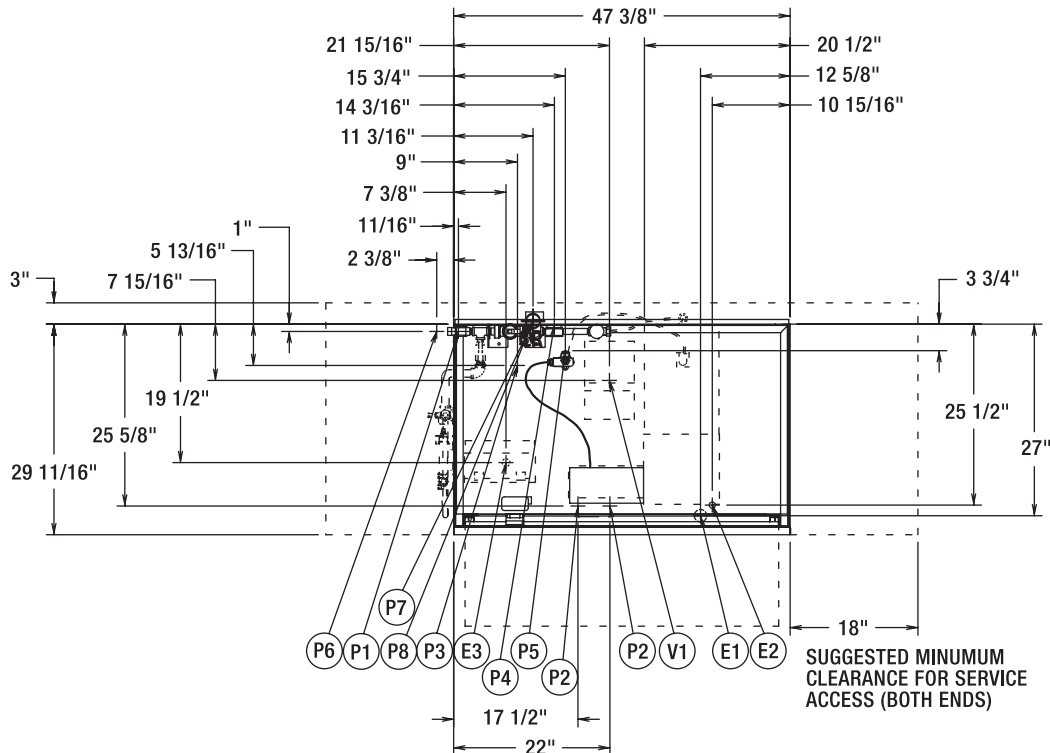

SUGGESTED MINIMUM
CLEARANCE FOR SERVICE
ACCESS (BOTH ENDS)

MODEL: UW-50
STEAM
00-812969
REV D

UW50 UTENSIL/PAN WASHER



701 S Ridge Avenue, Troy, OH 45374
1-888-4HOBART • www.hobartcorp.com

SPECIFICATIONS

DESIGN: Heavy-duty, fully automatic, front-loading utensil/pan washer with large split door system. Upper door section slides upward as the lower door section is pulled down. Stainless steel pull-out rack allows easy loading for large utensils and pans. Three variable wash cycles ensure thorough cleaning and sanitizing.

CONSTRUCTION: Stainless steel tank and hood, frame, legs and adjustable feet. Front enclosure panel standard.

PUMP: Cast iron pump integral with motor, Ni-Resist impeller, horizontally mounted. Pump capacity 343 gpm.

MOTOR: 5 H.P., available in 208/60/3, 240/60/3, or 480/60/3 configurations. Factory sealed lubrication, drip proof with sealed ball bearings. Thermal overload protection.

RACKS PER HOUR:

Wash Cycle	Racks/Hr.
2 minute	19
4 minute	12
6 minute	9

WASH CYCLE: Complete automatic operation. Cycle may be interrupted any time by opening door. The selected cycle will restart from the beginning when door is closed again.

Upper and lower revolving stainless steel wash arms, with computer designed, debossed, anti-clog wash nozzles, direct high pressure wash flow to all soiled surfaces.

Large, sloping, perforated, removable stainless steel scrap screens direct food soils to a deep perforated stainless steel scrap basket.

Scrap basket and strainer easily removed.

RINSE CYCLE: 180°F final sanitizing rinse through two upper and two lower revolving stainless steel rinse arms. Rinse arms removable without tools.

WATER USAGE PER RACK:

2.1 gallons per rack

RACKING: Standard rack assortment consists of one flat-bottomed frame rack, one flat grid insert rack, and two tray support insert racks. External rack dimensions are 40 $\frac{7}{8}$ " wide, 22 $\frac{7}{8}$ " deep, and 4 $\frac{1}{8}$ " high.

Standard flat-bottomed frame rack also accepts (2) 20" x 20" combination or peg racks per cycle.

SPECIFICATIONS: Listed by Underwriters Laboratories Inc., NSF International and CUL.

As continued product improvement is a policy of Hobart, specifications are subject to change without notice.